

MAX series Solar Controller

12/24V, 10/20A



User Manual

User Manual_Max series_NJ
CE, Rohs, ISO9001:2015
Subject to change without notice!

Solar charge controller MAX series User Manual

Dear Clients,

Thank you for purchasing our MAX series solar controller. This product manual provides some important advice related to the controller, including installation, programming and troubleshooting. Please read this manual carefully before using this product.

1. Overview

Outstanding features:

- LCD display design, read operating data and working condition easily.
- 12/24 automatic recognition.
- Built-in over-temperature protection mechanism, the temperature exceeds the set value to the charging current drop operation.
- Automatic limit function of rated charging current.
- Flexible System battery selection: Liquid, Gel, AGM and Lithium.
- Lead-acid battery charging in four stages: fast charge, boost charge, equalization charge, float charge.
- PWM charging is programmable to prevent system failure caused by BMS.
- Short-circuit protection is programmable to prevent output shutdown when opening the capacitive or inductive loads.
- Small size, PID algorithm adopt to control the voltage output, make the control more stable and accurate.
- The optical control point voltage and charging voltage can be set.
- Perfect EMC & thermal design.

2. Safety instructions and waiver of liability

2.1 Safety Instructions

The following symbols are used throughout this manual to indicate potentially dangerous conditions or mark important safety instructions. Please take care when meeting these symbols.

⚠️ WARNING: Indicates a potentially dangerous condition. Use extreme caution when performing this task.

⚠️ CAUTION: Indicates a critical procedure for safe and proper operation of the controller.



WARNING:

- 1) There are no user serviceable parts inside the controller. Do not disassemble or attempt to repair the controller.
- 2) Install the controller in a well-ventilated place because the heat sink temperature is very high.
- 3) Keep children away from batteries and the charge controller.

2.2 Liability Exclusion

The manufacturer shall not be liable for damages, especially on the battery, caused by use other than as intended or as mentioned in this manual or if the recommendations of the battery manufacturer are neglected. The manufacturer shall not be liable if there has been service or repair carried out by any unauthorized person, unusual use, wrong installation, or bad system design.

3. Dimensions (unit: mm)

Unit: mm

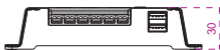
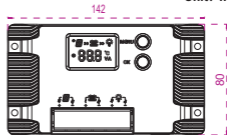

MAX1024-U/MAX2024-U



MAX1024/MAX2024

4. Connection and grounding

4.1 Connection

We strongly recommend connecting a fuse directly to the battery terminal to protect from any short circuit in the battery circuit. PV-modules generate current whenever light shines on them. The generated current is directly proportional to the light intensity. Even low levels of light, will deliver the PV-Modules no load, full voltage. It is thus utterly advisable to protect PV-modules from any incident light during installation; Never touch uninsulated cables(ends), only use electric insulated tools, and make sure that the wire cross section is adequate for the PV module operating currents. Connections must always be conducted in the sequence as described below.

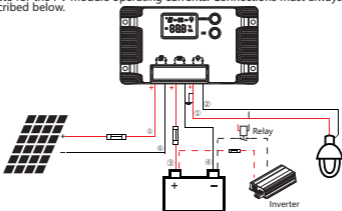

Warning: High pressure danger! Solar cell modules may produce a high open circuit voltage, to disconnect the circuit breaker or fuse before wiring, the wiring process must be careful.



WARNING: Risk of explosion! In case the battery's positive and negative terminals or leads get ever in touch, i.e. short-circuited, a fire or explosion hazard might get triggered. Always pay maximum when handling batteries and related circuits.



The load end is prohibited from accessing the inductive load.



CAUTION: 1.Should the temperature sensor be short-circuited or damaged, the controller can charge or discharge the battery at the default 25 °C.
2.If a power inverter is used the system, it should be connected to the battery via a DC relay. Do not connect it to the controller's load terminals.

1st step: Connect loads

Connect the load cable with the correct polarity of the right-hand side pair of terminals on the solar charge controller (with the lamp symbol). To avoid the presence of any tension on the cable/wires, please connect these first to the load before connecting them to the charge controller.

2nd step: Connect the battery

Connect the battery cable to the two terminals in the middle of the controller with the correct polarity (the controller is marked with the battery icon).

1)Should your system be nominal 12 Vdc, make sure the battery voltage is between the 10.0 and 15.0 Vdc voltage range;

2)For 24 Vdc nominal voltage, the battery voltage should be within the 20.0 to 30.0 Vdc range; If the polarity is correct, the LCD on the controller will begin to display those.

3rd step: Connect the solar module

When connecting the PV-Module make sure to cover it from incident sun light. Double check the PV-Module will not exceed the maximum permissible input current of the Charge Controller (please refer to the section Technical Data). Connect the solar module connection cable to the correct polarity of the left pair of terminals on the solar charge controller (with the solar module symbol).

4th step: Final work

Tighten all cables connected to the controller and remove all the remains around the controller (leaving avoid of minimum 15 cm).

4.2 Grounding

Be aware that the positive terminals of controller are interconnected and therefore bear the same electrical potential. If any grounding is required, always do this on the positive wires/terminals.

5. Operation





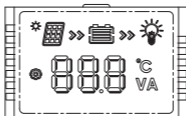

5.1 Key function

Mode	Operating
Browse interface	Short press OK .
Static display	Press the MENU and OK key at the same time for 1s, the LCD screen will lock the interface. Press the OK key, the LCD interface will unlock and start scrolling.
Setting parameter	Press the MENU key for 1s to enter the setting mode when the icon  appears on the display interface, and exit automatically after 30s.
Load On/Off	When the controller is working in street lamp mode, press the MENU key for 3s to turn on the load, press the MENU key again or 1min later the load will be turned off.

5.2 LCD Display



5.2.1 Status Description

Item	Icon	Status
PV array	  	Daytime, charging
Battery		Battery capacity Indicate low voltage protection, 25%、50%、75%、100%
Load	 	Load on, discharge
Other description		Units are placed after the numbers: Hours (H), Minutes (M), Seconds (S), Voltage (V)

5.2.2 The interface automatically cycles in the displayed sequence

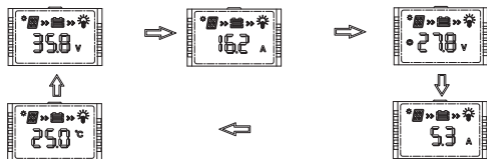



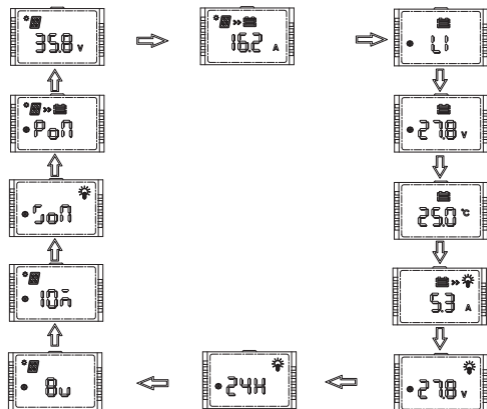





5.2.3 Press OK to browse the interface



A	B	C	D	E	F	G	H	I	J	K	L	M	N	O	P	Q	R
A	b	c	d	E	F	G	H	I	J	K	L	M	N	O	P	Q	R
S	T	U	V	W	X	Y	Z	0	1	2	3	4	5	6	7	8	9
5	t	U	v	y	Y	2	0	1	2	3	4	5	6	7	8	9	

5.2.4 Fault indication

Status	Icon	Description
Load short circuit	 E01	Load off, load icon flashes, the LCD screen displays E01.
Load over current	 E02	Load off, load icon flashes, the LCD screen displays E02.
Battery low voltage	 E03	Battery level shows empty, battery frame flashes, the LCD screen displays E03.
Battery over voltage	 E04	Battery level shows full, battery flashes, the LCD screen displays E04.
Over temperature	 E05	The charge and discharge are off, icon °C flashing, the LCD screen displays E05.
PV over voltage	 E06	PV level shows high, PV frame flashes, the LCD screen displays E06.
PV over current	 E07	Overcurrent, PV frame flashes, the LCD screen displays E07.
PV short circuit	 E08	PV short circuit, PV frame flashes, the LCD screen displays E08.

5.3 Parameters setting

When the icon  appears in the display interface, it means that the parameters can be set. Press the MENU key for 1s, then icon  flashes, Press the OK key to raise the parameters, and press the MENU key to lower the parameters. Press and hold the MENU key for 1 second to exit.

5.3.1 PV voltage&Charging current



Display PV voltage



Display charging current

5.3.2 Battery type

Choosing Lithium,AGM, GEL or Liquid for battery type



Display	Battery type
GEL	GEL(Default)
LIQ	Liquid
AGM	AGM
LI	Lithium

1.Charging Voltage Parameters(Liquid, GEL, AGM)

When choosing Liquid, GEL or AGM for battery type,the parameters of boost, equalization and float charge voltage can be set by pressing the button. The range of parameters is as follows. The following voltage parameters are 25°C/12V system parameters, 24V displayed values are multiplied by a factor of 2.

Charging stage	Boost	Equalization	Float
Charging Voltage Range	14.0~14.8V	14.3~15.0V	13.2~14.0V
Default charging voltage	14.5V	14.8V	13.7V

2.Charging Voltage Parameters(Lithium)

When the battery type is lithium battery, the lithium overcharge protection voltage can be set by pressing the button.

5.3.3 Overcharge protection voltage (lithium battery)/boost voltage (other battery types)



1. When the battery type is lithium battery, you can set the lithium battery overcharge protection voltage on the current screen. Setting range: 12/24V: 10.1~32.0V (default 14.4V)
Note: The controller automatically calculates the overcharge recovery voltage according to the overcharge protection voltage, and the overcharge recovery voltage is $\approx(0.97 \times \text{overcharge protection voltage})$.

2. When the battery type is AGM/GEL/LIQ, you can set the boost voltage on the current screen. The equalization voltage is boost voltage +0.3V(12V system)/+0.6V(24V system). The float voltage is boost voltage -0.8V/1.6V.

Note: The GEL battery is not have equalization.

5.3.4 Low voltage protection



1. When the battery type is lithium battery, you can set the lithium battery low voltage protection voltage on the current screen. Setting range : 9.0~30.0V (default 10.6V)

Note: The controller automatically calculates the low-voltage recovery voltage according to the set low-voltage protection voltage. The low-voltage recovery voltage is $\approx 1.11 \times \text{low-voltage protection voltage}$.

2. When the battery type is GEL/LIQ/AGM,
Setting range : 10.8~11.8V/21.6~23.6V (default 11.2/22.4V)

Note: The default low-voltage recovery voltage of the controller is 0.8V/1.6V higher than the low-voltage protection voltage. To reduce the low-voltage recovery voltage, lower the low-voltage protection voltage first.

5.3.5 Load mode



Universa type controller, 24H output (default).

When the controller is set to 24H output mode, there is always an output at the load end regardless of the charging or discharging state (except the protection state).

Note: The test function is not valid in this state



Dusk to Dawn Mode (D2D)



Lighting time at night (time 1~12 hours); 01 to 12 corresponds to 1 to 12 hours
Light control priority, when the PV voltage > Optically controlled spot, then shut down the load.



Lighting time in the day (time 1~12 hours); 01 to 12 corresponds to 1 to 12 hours
The load is turned off at night, and the load is turned off after the lighting period is performed during the day.



If the load mode is selected "USE", then you can switch on and off the load output manually by pressing **MENU** shortly.



1.If the controller turns off the load due to low voltage protection, overcurrent protection, short-circuit protection or over temperature protection, the load will turn on automatically when the controller recovers from protection state.

2.Please note: Pushing the MENU button can still activate the function of the key, even during of the above four kinds protection states.

5.3.6 Optically controlled spot



The controller automatically identifies day and night by measuring the open circuit voltage of the solar panel. Depending on the location and the different solar panels, the user can set different day/night threshold voltage).

Liquid, GEL, AGM:The voltage setting range:3.0~10.0V/6.0~20.0V(default:8.0/16.0V).

Lithium:The voltage setting range:3.0~20.0V(default:8.0V).

5.3.7 Optical delay



When the night comes, the controller identifies the day/night threshold voltage.

Through modifying the "day/ night threshold delay" to put off the lighting time.

Setting range is 0~60 seconds (step length is 5 seconds) and 1~30 minutes (step length is 1 minute) (the default setting is 0 seconds).

5.3.8 Short circuit protection



When the inductive or capacitive load is started, there will be a large current, which may trigger the short-circuit protection of the controller and cause the output to turn off. In this case, the user can turn off the short-circuit protection function. SoN is enabled, SoF is disabled, and the default state is enabled.

Setting info : keep the defaults.

5.3.9 PWM charging Settings (Lithium batteries)











PWM has the potential to cause noise and interference in the system, especially when using lithium batteries with BMS, PWM charging may trigger BMS protection ,resulting in system failure. Therefore, the customer can choose to turn off the PWM, in this mode once the battery voltage is charged to the preset voltage, the controller immediately stops charging, until the battery voltage drops, and then restart the charging. PoN is enabled, PoF is disabled, and the default value is enabled.

Setting info : keep the defaults.

6. Troubleshooting

6.1 Troubleshooting

Faults	Reason	Troubleshooting
 E01	Load short circuit	①Clear short circuit fault ②Restart the controller or press the key to restore the load output.
 E02	Load over current	①Power reduction equipment ②Restart the controller or press the button to clear the faulty load and restore output.
 E03	Battery low voltage	Load will be reconnected when battery is recharged.
 E04	Battery over voltage	Check if other sources overcharge the battery. If not, controller is damaged.
 E05	Over temperature	After the temperature decreases, the controller will work normally.
 E06	PV over voltage	Reduce solar photovoltaic voltage or shield the solar panel appropriately.
 E07	PV over current	Check whether the solar panel power exceeds the maximum power limitation. If yes, change the solar panel.
 E08	PV short circuit	Check whether the solar panel is damaged. If so, replace the photovoltaic panel.

Two or more errors at the same time can damage the controller, so you must troubleshoot the existing fault.

6.2 Maintenance

For best system performance, the following inspections and maintenance tasks are recommended to be carried out for at least two times a year.

- Make sure no block on air-flow around the controller. Clear up any dirt and fragments on radiator.
- Check all the naked wires to make sure insulation is not damaged.
- Repair or replace some wires if necessary.
- Tighten all terminal screws to the indicated torque; Inspect for loose, broken or burnt cable connections.
- Check and confirm that LCD is consistent with required. Pay attention to any troubleshooting or error indication. Take corrective action if necessary.
- Make sure all system components are effectively and tightly connected to ground.
- Check all terminals for any corrosion signs, damaged insulation, increased temperature.
- Check for any dirt, nesting insects and any corrosion signs. Implement corrections actions as early as possible.



WARNING: Risk of electric shock!

Make sure that all the power is turned off before above operations, and then follow the corresponding inspections and operations.

7, Technical Data

7.1 Parameter

	Item	MAX1024-U	MAX2024-U	
Battery Parameters	Max Charging Current	10A	20A	
	System Voltage	12/24V automatic recognition		
	Max volt on Bat. terminal	35V		
	Battery Type	Gel, AGM, Liquid, Lithium (default: Gel)		
	Liquid, Gel and	Fast Charging Voltage	< 14.5/29.0V @25°C	
		Boost Voltage	14.0~14.8V/28.0~29.6V@25°C(default:14.5/29.0V)	
		Equalization Voltage	14.3~15.0V/28.6~30.2V@25°C(default:14.8/29.6V) (Liquid, AGM)	
	AGM	Float Voltage	13.2~14.0V/26.4V~28.0V@25°C(default:13.7/27.4V)	
		Low Volt. Disconnect	10.8~11.8V/21.6~23.6V(default: 11.2/22.4V)	
		Overcharge Protect	15.8/31.3V	
	Lithium	Temp. Compensation	-4.17mV/K per cell (Boost, Equalization), -3.33mV/K per cell (Float)	
Charging target voltage		10.1~32.0V(default: 14.4V)		
	Low voltage disconnect	9.0~30.0V(default: 10.6V)		
Panel Parameters	Max volt on PV terminal	25V@12V;50V@24V		
	Dusk/Dawn detect volt.	3.0~10.0V/6.0~20.0V(default: 8.0/16.0V)		
Load	Output Current	10A	20A	
	USB interface	5V, 2A		
	Load mode	Always on(Default) , D2D, Light control mode, Time control mode, User-defind Mode		
System Parameters	Dimensions	142* 80 * 30mm		
	Weight	190g		
	Grounding	Common Positive		
	Power terminals	8AWG(10mm ²)		
	Ambient temperature	-20 ~ +50°C		
	Storage temperature	-25 ~ +80°C		
	Protection degree	IP32		
Max Altitude	4000m			

* Around oblique line value separately on behalf of 12V and 24V system's value.

7, Technical Data

7.1 Parameter

	Item	MAX1024	MAX2024	
Battery Parameters	Max Charging Current	10A	20A	
	System Voltage	12/24V automatic recognition		
	Max volt on Bat. terminal	35V		
	Battery Type	Gel, AGM, Liquid, Lithium (default: Gel)		
	Liquid, Gel and	Fast Charging Voltage	< 14.5/29.0V @25°C	
		Boost Voltage	14.0~14.8V/28.0~29.6V@25°C(default:14.5/29.0V)	
		Equalization Voltage	14.3~15.0V/28.6~30.2V@25°C(default:14.8/29.6V) (Liquid, AGM)	
	AGM	Float Voltage	13.2~14.0V/26.4V~28.0V@25°C(default:13.7/27.4V)	
		Low Volt. Disconnect	10.8~11.8V/21.6~23.6V(default: 11.2/22.4V)	
		Overcharge Protect	15.8/31.3V	
	Lithium	Temp. Compensation	-4.17mV/K per cell (Boost, Equalization), -3.33mV/K per cell (Float)	
Charging target voltage		10.1~32.0V(default: 14.4V)		
	Low voltage disconnect	9.0~30.0V(default: 10.6V)		
Panel Parameters	Max volt on PV terminal	25V@12V;50V@24V		
	Dusk/Dawn detect volt.	3.0~10.0V/6.0~20.0V(default: 8.0/16.0V)		
Load	Output Current	10A	20A	
	USB interface	——		
	Load mode	Always on(Default) , D2D, Light control mode, Time control mode, User-defind Mode		
System Parameters	Dimensions	142* 80 * 30mm		
	Weight	190g		
	Grounding	Common Positive		
	Power terminals	8AWG(10mm ²)		
	Ambient temperature	-20 ~ +50°C		
	Storage temperature	-25 ~ +80°C		
	Protection degree	IP32		
Max Altitude	4000m			

* Around oblique line value separately on behalf of 12V and 24V system's value.